



Lite/Unmanaged Industrial Gigabit Ethernet Switch

Quick Installation Guide

Overview

The lite/unmanaged Industrial Gigabit Ethernet Switch solutions are designed for supporting standard industrial applications without complex setup to make the network truly plug-and-play.

Package Checklist

Please verify that the box contains the following items:

Item	Quantity
Unmanaged switch	1
Wall-mount plates	2
DIN-Rail CLIP	1
M4 Screws (for the wall mount plates & DIN CLIP)	4
DC power terminal block	1
Quick Installation Guide	1

Safety Instructions

When a connector is removed during installation, testing, or servicing, or when an energized fiber is broken, a risk of ocular exposure to optical energy that may be potentially hazardous occurs, depending on the laser output power.

The primary hazards of exposure to laser radiation from an optical-fiber communication system are:

- Damage to the eye by accidental exposure to a beam emitted by a laser source.
- Damage to the eye from viewing a connector attached to a broken fiber or an energized fiber.

Documentation Conventions

The following conventions are used in this quick installation guide to emphasize information that will be of interest to the reader.

Danger — The described activity or situation might or will cause *personal injury*.

Warning — The described activity or situation might or will cause *equipment damage*.

Caution — The described activity or situation might or will cause *service interruption*.

Note — The information supplements the text or highlights important points.

Technical Specifications

Model	5-Port	5-Port with PoE	8-Port
Ethernet			
Copper RJ45 Ports	10/100/1000 Mbps speed auto-negotiation; MDI/MDIX Auto-crossover		
SFP (pluggable) Ports	100/1000BaseSFP slot		
Fiber port connector	LC typically for fiber (depends on module)	LC typically for fiber	LC typically for fiber (depends on module)
PoE	NA	IEEE 802.3at PoE PSE	NA
Power			
Power input	Redundant Input Terminals; Reverse power protection		
Input voltage range	12-58 VDC	12-58 VDC, 54-58V for PoE+, 48-58V for PoE	12-58 VDC
Environmental and Compliances			
Operating temperature	-40 to +75°C (cold startup at -40°C)	-40 to +75°C (cold startup at -40°C)	-40 to +75°C (cold startup at -40°C)
Storage temperature	-40 to +85°C		
Humidity	5 to 95% RH (non-condensing)		
Mechanical			
Ingress protection	IP30		
Dimension (without DIN rail clip)	112.2mm(H) x 29.1mm (W) x 89.4mm (D)	139mm(H) x 29.1mm (W) x 107mm (D)	117.8mm(H) x 39mm (W) x 96.9mm (D)
Weight	329g	469g	439g
Installation option	DIN-Rail mounting Wall mounting		

ISON

Dimension Illustration

5-Port series

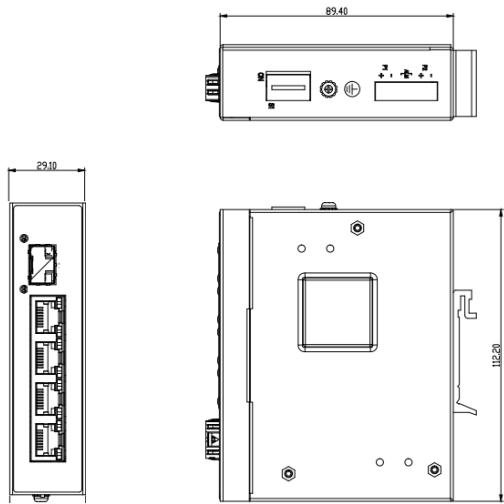

5-Port with PoE series

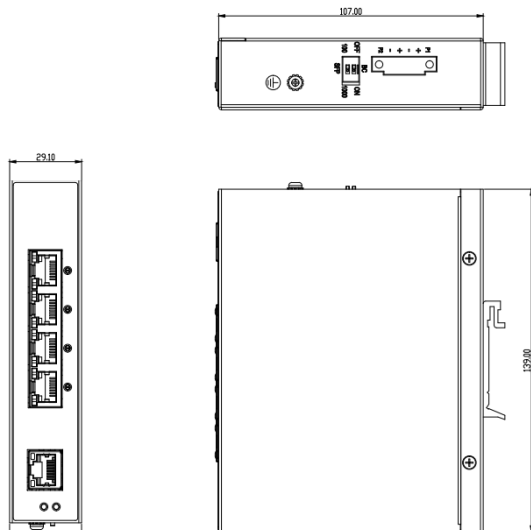

8-Port series

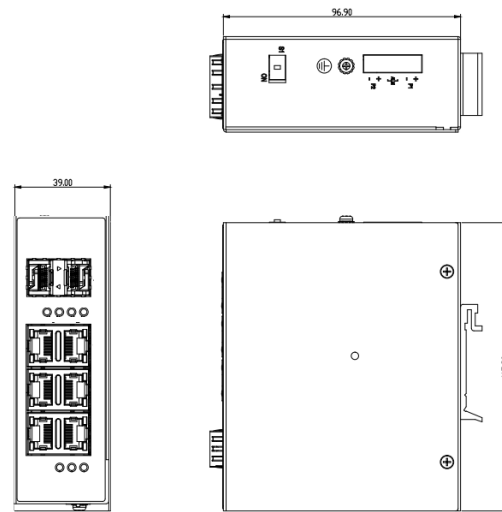

DIN-Rail Mounting

Mounting step:

1. Screw the DIN-Rail bracket on with the bracket and screws in the accessory kit.
2. Hook the unit over the DIN rail.
3. Push the bottom of the unit towards the DIN Rail until it snaps into place.

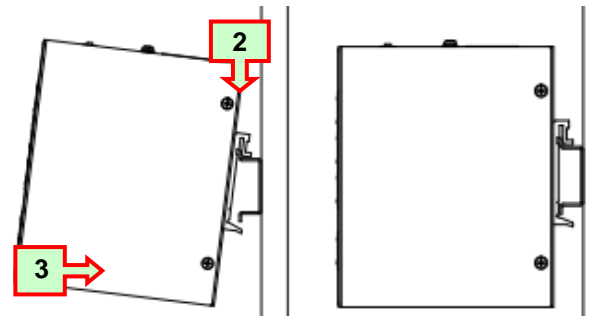

Wall Mounting

Mounting step:

1. Screw on the wall-mount plate on with the plate and M4 screws in the accessory kit.

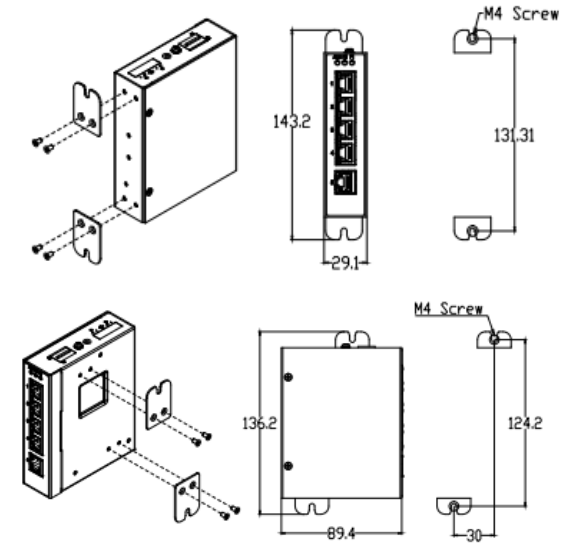



Ground Connecting

The switch must be properly grounded for optimum system performance.

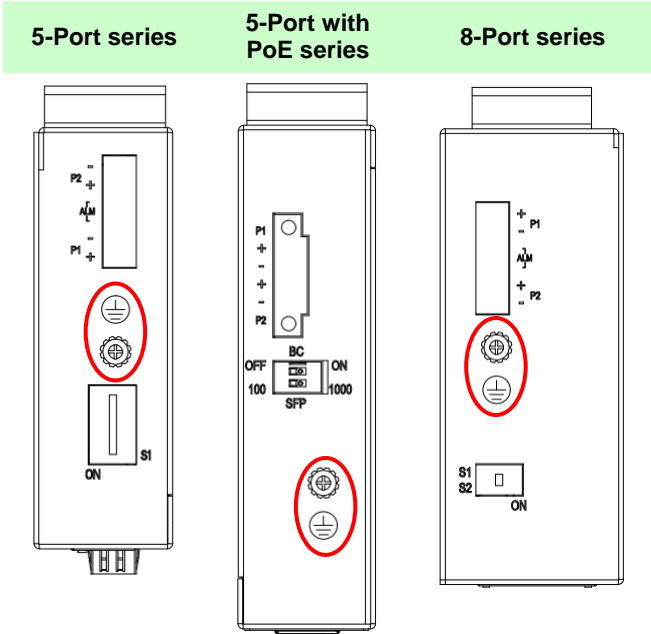

Ethernet Interface Connecting (RJ45 Ethernet)

The switches provide two types of electrical (RJ45) and optical (mini-GBIC) interfaces.

Connecting the Ethernet interface via RJ45:

- To connect to a PC, use a straight-through or a cross-over Ethernet cable,
- To connect the switch to an Ethernet device, use UTP (Unshielded Twisted Pair) or STP (Shielded Twisted Pair) Ethernet cables.

The pin assignment of RJ-45 connector is shown in

the following figure and table.

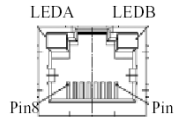

Pin	Assignment	PoE Assignment
1,2	T/Rx+,T/Rx-	Positive V _{Port}
3,6	T/Rx+,T/Rx-	Negative V _{Port}
4,5	T/Rx+,T/Rx-	X
7,8	T/Rx+,T/Rx-	X

Ethernet Interface Connecting the (Fiber, SFP)

For a 100 Mbps fiber port available, please prepare the LC connectors or SC connectors (with the use of an optional SC-to-LC adapter). They are also available with multimode, single mode, long-haul (for connections up to 120+ km) or special-application transceivers.

For a 1000 Mbps fiber port available, please use the mini-GBIC SFP (small form pluggable). These accept plug in fiber transceivers that typically have an LC style connector. They are available with multimode, single mode, long-haul (for connections up to 80+ km) or special-application transceivers.

For each fiber port there is a transmit (TX) and receive (RX) signal. Please make sure that the transmit (TX) port of the switch connects to the receive (RX) port of the other device, and the receive (RX) port of the switch connects to the transmit (TX) port of the other device when making your fiber optic connections.

DANGER: Never attempt to view optical connectors that might be emitting laser energy.

Do not power up the laser product without connecting the laser to the optical fiber and putting the cover in position, as laser outputs will emit infrared laser light at this point.

Power Connecting

The switch can be powered from two power supply (input range 12V – 58V). Insert the positive and negative wires into V+ and V- contact on the terminal block and tighten the wire-clamp screws to prevent the wires from being loosened.

- Note:**
1. The DC power should be connected to a well-fused power supply.
 2. Input power should be within the range of 54-58VDC for PoE+ compliant, or 48-58VDC for PoE compliant.

Alarm Relay Connecting (for Non-PoE Models)

The alarm relay output contacts are in the middle of the DC terminal block connector as shown in the figure below.

By inserting the wires and set the DIP switch of the respective Port Alarm to “ON”, the relay output alarm will detect any port failures, and form a short circuit.

The alarm relay output is “Normal Open”.

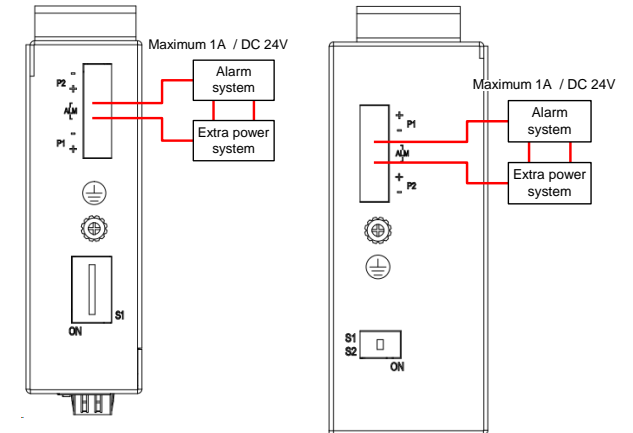



DIP Switch Setting

Pin No#	Status	5-Port (5TX) (Unmanaged)	5-Port (4TX+1SFP) (Unmanaged)	5-Port (5TX) (Lite-managed)
Pin 1	ON	To enable the power alarm.	To enable the power alarm.	To enable the power alarm.
	OFF	To disable the power alarm.	To disable the power alarm.	To disable the power alarm.
Pin 2	ON	To enable Broadcast storm rate limit	To enable Broadcast storm rate limit	To enable Broadcast storm rate limit / flow control
	OFF	To disable Broadcast storm rate limit	To disable Broadcast storm rate limit	To disable Broadcast storm rate limit / flow control
Pin 3	ON	NOT USED	NOT USED	To enable Ring on port 1 and port 2
	OFF	NOT USED	NOT USED	To disable Ring on port 1 and port 2
Pin 4	ON	NOT USED	NOT USED	To enable Ring on port 3 and port 4
	OFF	NOT USED	NOT USED	To disable Ring on port 3 and port 4
Pin 5	ON	NOT USED	NOT USED	To enable the LLDP
	OFF	NOT USED	NOT USED	To disable the LLDP
Pin 6	ON	NOT USED	NOT USED	NOT USED
	OFF	NOT USED	NOT USED	NOT USED

Pin No#	Status	5-Port (5TX) with PoE	5-Port (4TX+1SFP) with PoE
Pin 1	ON	To enable Broadcast storm rate limit	To enable Broadcast storm rate limit
	OFF	To disable Broadcast storm rate limit	To disable Broadcast storm rate limit
Pin 2	ON	NOT USED	NOT USED
	OFF	NOT USED	NOT USED

Pin No#	Status	8-Port (8TX)	8-Port (6TX+2SFP)
Pin 1	ON	To enable Broadcast storm rate limit	To enable Broadcast storm rate limit
	OFF	To disable Broadcast storm rate limit	To disable Broadcast storm rate limit
Pin 2	ON	To enable the power alarm.	To enable the power alarm.
	OFF	To disable the power alarm.	To disable the power alarm.

LED STATUS INDICATIONS

LED Name	Indicator /color	Condition
PoE	On Green	PoE is working
	Off	PoE is not working
P1	On Green	P1 power line has power
	Off	P1 power line disconnect or does not have supply power
P2	On Green	P2 power line has power
	Off	P2 power line disconnect or does not have supply power
Alarm	On Red	Power failure alarm occurs
	Off	No power failure alarm
Copper 1 to N port Link/Act	On Green	Ethernet link up but no traffic is detected
	Flashing Green	Ethernet link up and there is traffic detected
	Off	Ethernet link down
Copper 1 to N port Speed	On Yellow	A 1000Mbps connection is detected
	Off	No link, a 10Mbps or 100 Mbps connection is detected
SFP 1 to N port (N=0,1,2) Link/Act	On Green	Ethernet link up
	Off	Ethernet link down
SFP 1 to N port (N=0,1,2) Speed	On Yellow	SFP port speed 1000Mbps connection is detected.
	Off	No link or a SFP port speed 100Mbps connection is detected.