

Specification

Small Form Factor Pluggable

Duplex LC Receptacle – SFP+

Optical Transceivers

10 Gigabit Ethernet

10GBASE-SR



Ordering Information

T A S - A 1 N H 1 - P A H

Voltage / Temperature
 1 : 3.3V / 0°C~+70°C

Model Name	Voltage	Category	Device type	Interface	LOS	Temperature	Distance	Latch Color
TAS-A1NH1-PAH	3.3V	With DDMI	850 nm VCSEL	AC / AC Coupling	LVTTL	0°C~+70°C	33m / 82m /300m (OM1/ OM2/OM3)	Black 

Features

- Optical interface compliant to IEEE 802.3ae 10GBASE-SR/SW
- Compliant with SFP+ MSA
- Data Rate 10.3125 Gbps
- 850nm VCSEL TOSA and PIN ROSA
- Maximum link length of 300m on 2000MHz-km MMF
- LC duplex receptacle
- Low power dissipation (<800 mW)
- Hot Pluggable
- All-metal housing for superior EMI performance
- Built in digital diagnostic functions
- Operating case temperature range: 0 ~ 70°C
- RoHS Compliant

Applications

- 10GBASE-SR 10Gigabit Ethernet
- High-speed storage area networks
- Computer cluster cross-connect
- Custom high-speed data pipes
- Inter Rack Connection

Fiber type	Minimum modal bandwidth @ 850 nm (MHz•km)	Operating range (meters)
62.5 μm MMF	160	2 to 26
	200	2 to 33
50 μm MMF	400	2 to 66
	500	2 to 82
	2000	2 to 300

Transceiver Block Diagram

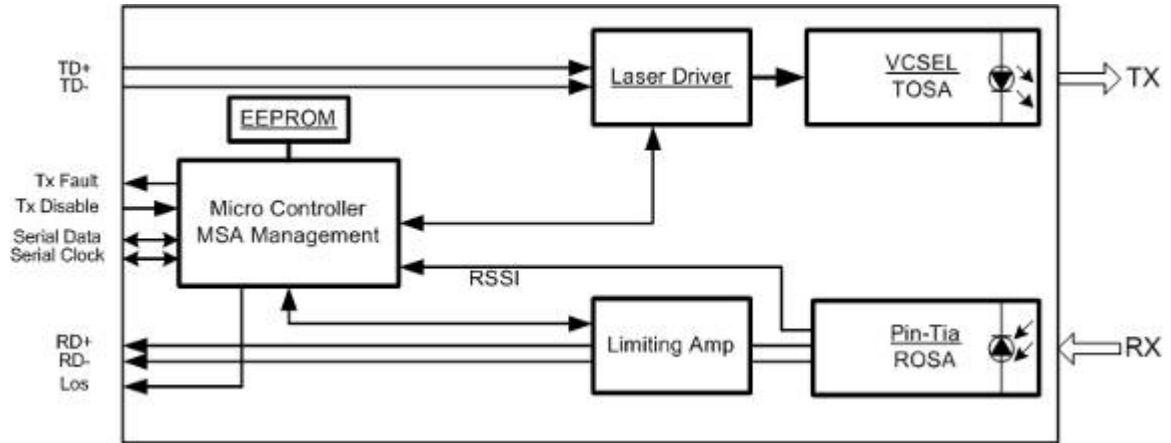

Proposed Applications Schematics

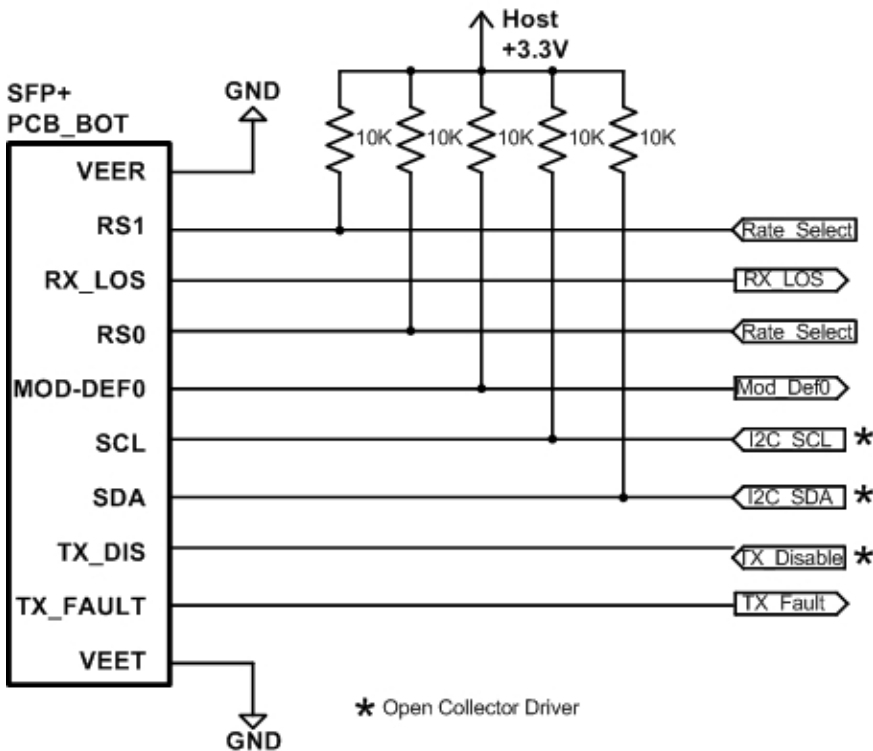
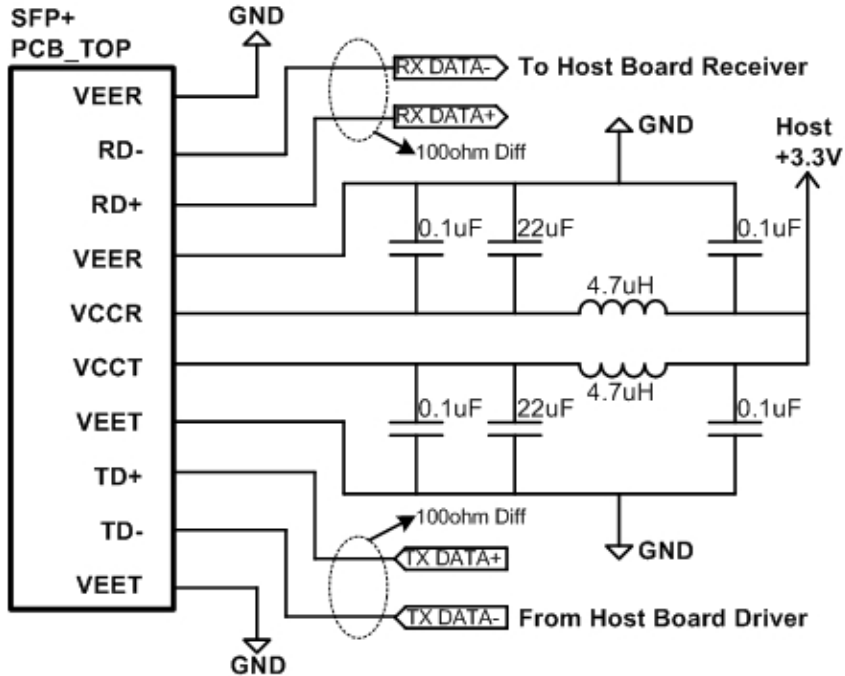

Pin Definition and Descriptions

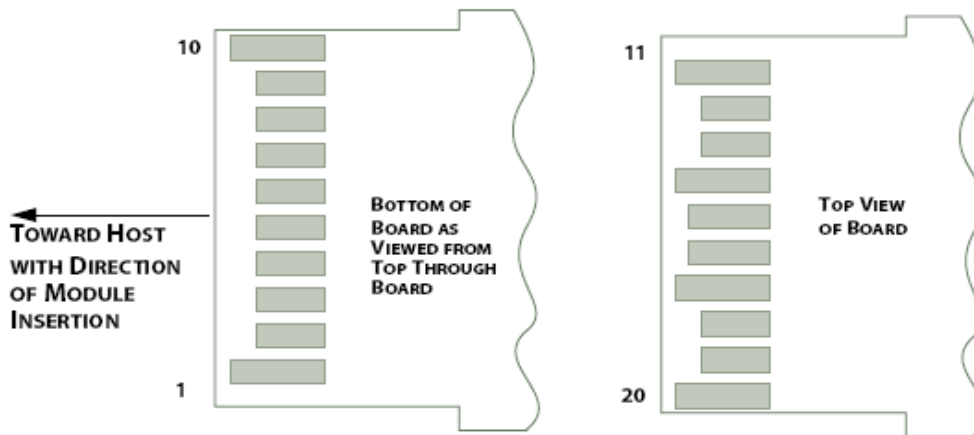
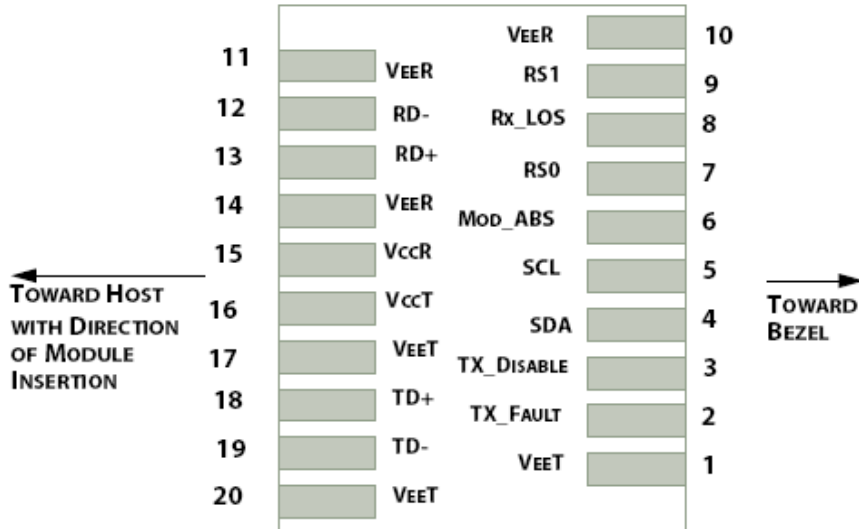

PIN	Logic	Symbol	Name / Description	Note
1		VeeT	Module Transmitter Ground	1
2	LVTTL-O	TX_Fault	Module Transmitter Fault	2
3	LVTTL-I	TX_Dis	Transmitter Disable; Turns off transmitter laser output	3
4	LVTTL-I/O	SDA	2-Wire Serial Interface Data Line	
5	LVTTL-I	SCL	2-Wire Serial Interface Clock	
6		Mod_ABS	Module Absent, connected to VeeT or VeeR in the module	2
7	LVTTL-I	RS0	Rate Select 0, optionally controls SFP+ module receiver. When high input signaling rate > 4.25 GBd and when low input signal rate \leq 4.25 GBd.	
8	LVTTL-O	RX_LOS	Receiver Loss of Signal Indication	2
9	LVTTL-I	RS1	Rate Select 1, optionally controls SFP+ module transmitter. When high input signaling rate > 4.25 GBd and when low input signal rate \leq 4.25 GBd.	
10		VeeR	Module Receiver Ground	1
11		VeeR	Module Receiver Ground	1
12	CML-O	RD-	Receiver Inverted Data Output	
13	CML-O	RD+	Receiver Data Output	
14		VeeR	Module Receiver Ground	1
15		VccR	Module Receiver 3.3 V Supply	
16		VccT	Module Transmitter 3.3 V Supply	
17		VeeT	Module Transmitter Ground	1
18	CML-I	TD+	Transmitter Non-Inverted Data Input	
19	CML-I	TD-	Transmitter Inverted Data Input	
20		VeeT	Module Transmitter Ground	1

Note:

1. Module ground pins are isolated from the module case and chassis ground within the module.
2. Shall be pulled up with 4.7k to 10k ohm to a voltage between 3.15V and 3.45V on the host board.
3. Shall be pulled up with 4.7k to 10k ohm to VccT in the module.

Absolute Maximum Ratings

Parameters	Symbol	Min.	Max.	Unit
Power Supply Voltage	V_{CC}	0	3.6	V
Storage Temperature	T_c	-40	85	°C
Relative Humidity	RH	5	95	%
Optical Receiver Power (Damage)		-	4	dBm

Recommended Operating Environment

Parameters	Symbol	Min.	Typical	Max	Unit
Power Supply Voltage	V_{CC}	3.135	3.3	3.465	V
Operating Case Temperature	T_c	0	25	70	°C

Optical Characteristics

The following optical characteristics are defined over the Recommended Operating Environment unless otherwise specified.

Parameter	Symbol	Min.	Typical	Max	Unit	Notes
Transmitter						
Center Wavelength	λ_t	840	850	860	nm	
RMS spectral width	Pm	-	-	Note 1	nm	
Average Optical Power	Pavg	-6.5	-	-1	dBm	
Optical Power OMA	Poma	-	-	Note 1	dBm	
Laser Off Power	Poff	-	-	-30	dBm	
Extinction Ratio	ER	3.5	-	-	dB	
Transmitter Dispersion Penalty	TDP	-	-	3.9	dB	
Relative Intensity Noise	Rin	-	-	-128	dB/Hz	12dB reflection
Optical Return Loss Tolerance		-	-	12	dB	
Receiver						
Center Wavelength	λ_r	840	850	860	nm	
Receiver Sensitivity (OMA)	Psens	-	-	-11.1	dBm	
Stressed Sensitivity (OMA)		-	-	-7.5	dBm	
Los Assert	LosA	-30	-	-	dBm	
Los Dessert	LosD	-	-	-12	dBm	
Los Hysteresis	LosH	0.5	-	-	dB	
Overload	Pin	-	-	-1	dBm	
Receiver Reflectance		-	-	-12	dB	

Note:

1. Trade-offs are available between spectral width, center wavelength and minimum OMA, as shown in follow table.

Center Wavelength (nm)	RMS Spectral width (nm)								
	Up to 0.05	0.05 to 0.1	0.1 to 0.15	0.15 to 0.2	0.2 to 0.25	0.25 to 0.3	0.3 to 0.35	0.35 to 0.4	0.4 to 0.45
840 to 842	-4.2	-4.2	-4.1	-4.1	-3.9	-3.8	-3.5	-3.2	-2.8
842 to 844	-4.2	-4.2	-4.2	-4.1	-3.9	-3.8	-3.6	-3.3	-2.9
844 to 846	-4.2	-4.2	-4.2	-4.1	-4.0	-3.8	-3.6	-3.3	-2.9
846 to 848	-4.3	-4.2	-4.2	-4.1	-4.0	-3.8	-3.6	-3.3	-2.9
848 to 850	-4.3	-4.2	-4.2	-4.1	-4.0	-3.8	-3.6	-3.3	-3.0
850 to 852	-4.3	-4.2	-4.2	-4.1	-4.0	-3.8	-3.6	-3.4	-3.0
852 to 854	-4.3	-4.2	-4.2	-4.1	-4.0	-3.9	-3.7	-3.4	-3.1
854 to 856	-4.3	-4.3	-4.2	-4.1	-4.0	-3.9	-3.7	-3.4	-3.1
856 to 858	-4.3	-4.3	-4.2	-4.1	-4.0	-3.9	-3.7	-3.5	-3.1
858 to 860	-4.3	-4.3	-4.2	-4.2	-4.1	-3.9	-3.7	-3.5	-3.2

Digital Diagnostic Functions

The following digital diagnostic characteristics are defined over the Recommended Operating Environment unless otherwise specified. It is compliant to SFF8472 Rev10.2 with internal calibration mode. For external calibration mode please contact our sales staff.

Parameter	Symbol	Min.	Max	Unit	Notes
Temperature monitor absolute error	DMI_Temp	-3	3	degC	Over operating temp
Laser power monitor absolute error	DMI_TX	-3	3	dB	
RX power monitor absolute error	DMI_RX	-3	3	dB	-1dBm to -12dBm range
Supply voltage monitor absolute error	DMI_VCC	-0.08	0.08	V	Full operating range
Bias current monitor	DMI_Ibias	-10%	10%	mA	

Electrical Characteristics

The following electrical characteristics are defined over the Recommended Operating Environment unless otherwise specified.

Parameter	Symbol	Min.	Typical	Max	Unit	Notes
Data Rate		-	10.3125	-	Gbps	
Power Consumption		-	600	800	mW	
Transmitter						
Single Ended Output Voltage Tolerance		-0.3	-	4	V	
C common mode voltage tolerance		15	-	-	mV	
Tx Input Diff Voltage	VI	180		700	mV	
Tx Fault	VoL	-0.3		0.4	V	At 0.7mA
Data Dependent Input Jitter	DDJ			0.1	UI	
Data Input Total Jitter	TJ			0.28	UI	
Receiver						
Single Ended Output Voltage Tolerance		-0.3	-	4	V	
Rx Output Diff Voltage	Vo	300		850	mV	
Rx Output Rise and Fall Time	Tr/Tf	30			ps	20% to 80%
Total Jitter	TJ			0.7	UI	
Deterministic Jitter	DJ			0.42	UI	

Control And Status I/O Timing Characteristics

Timing characteristics of control and status I/O are included in Table 9, which is also defined in SFF-8431.

Parameter	Symbol	Min	Max	Unit	Condition
TX Disable Assert Time	t _{off}		10	μs	Time from rising edge of TX Disable to when the optical output falls below 10% of nominal
TX Disable Negate Time	t _{on}		1	ms	Time from falling edge of TX Disable to when the modulated optical output rises above 90% of nominal
Time to initialize, including reset of TX_Fault	t _{init}		300	ms	From power on or negation of TX Fault using TX Disable
TX Fault Assert Time	t _{fault}		100	μs	Time from fault to TX fault on.
TX Disable to reset	t _{reset}	10		μs	Time TX Disable must be held high to reset TX_fault
LOS Assert Time	t _{loss_on}		100	μs	Time from LOS state to RX LOS assert
LOS Deassert Time	t _{loss_off}		100	μs	Time from non-LOS state to RX LOS deassert
Rate-Select Change Time	t _{ratesel}		10	μs	Time from rising or falling edge of Rate Select input until receiver bandwidth is in conformance with appropriate specification.
Serial ID Clock Rate	f _{serial_clock}		100	KHz	



Content in 2-Wire Address A0H

Address	HEX	Name of Field	Description
00	03	Identifier	SFP
01	04	Extended Identifier	SFP
02	07	Connector type	LC
03	10	10G Ethernet Compliance Codes	10G Base SR
04	00	SONET Compliance Codes	Not compliant
05	00	SONET Compliance Codes	Not compliant
06	00	Ethernet Compliance Codes	Not compliant
07	00	Fiber Channel link length	Not compliant
08	00	Fiber Channel transmitter technology	Not compliant
09	00	Fiber Channel transmission media	Not compliant
10	00	Fiber Channel speed	Not compliant
11	06	Encoding codes:	64B/66B
12	67	Nominal Bit Rate (units of 100Mbps)	10.3Gbps
13	00	Rate identifier	Unspecified
14	00	Link length supported for 9um fiber	N/A (units of km)
15	00	Link length supported for 9um fiber	N/A (units of 100m)
16	08	Link length supported for 50um,OM2	82m (units of 10m)
17	03	Link length supported for 62.5um,OM1	33m (units of 10m)
18	00	Link length supported for copper	N/A (units of 1m)
19	1E	Link length supported for 50um,OM3	300m (units of 10m)
20 ~ 35	46,4F,52,4D,45,52,49,43,41,4F,45,20,20,20,20,20	Vendor Name	FORMERICA OE
36	00	Unallocated	
37 ~ 39	00,00,00	Vendor OUI	Unspecified
40 ~ 55	54,41,53,2D,41,31,4E,48,31,2D,50,41,48,20,20,20	Part Number	TAS-A1NH1-PAH
56 ~ 59	00,00,00,00	Vendor Revision number	Unspecified
60 ~ 61	03,52	Laser Wavelength	850nm
62	00	Unallocated	
63		CC_BASE:	Check sum of byte 0 ~ 62
64	00	Options	
65	1A	Options	TX-DIS, TX_FAULT, RX-LOS
66	00	Bit Rate, max.	Unspecified
67	00	Bit Rate, min.	Unspecified
68 ~ 83	Serial Number	Serial Number	
84 ~ 89	yy/mm/dd	Date Code	
90 ~ 91	20,20	Vendor specific lot code	Unspecified
92	68	Diagnostic Monitoring Type	Internal calibration
93	F0	Enhanced Options (soft)	Alarm/Warning flags, Soft TxDisable, Soft TxFault, Soft RxLOS implemented
94	03	SFF-8472 Compliance	Rev10.2
95		CC_EXT	Check sum of byte 64 ~ 94
96~127		Vendor specific	



Content in 2-Wire Address A2H

Add	Bytes	Name	Hex	Real Value
00-01	2	Temp High Alarm	5A00	90°C
02-03	2	Temp Low Alarm	EC00	-20°C
04-05	2	Temp High Warning	5500	85°C
06-07	2	Temp Low Warning	F100	-15°C
08-09	2	Voltage High Alarm	9470	3.8V
10-11	2	Voltage Low Alarm	6D60	2.8V
12-13	2	Voltage High Warning	9088	3.7V
14-15	2	Voltage Low Warning	7148	2.9V
16-17	2	Bias High Alarm	2710	20mA
18-19	2	Bias Low Alarm	00FA	0.5mA
20-21	2	Bias High Warning	2328	18mA
22-23	2	Bias Low Warning	01F4	1mA
24-25	2	TX Power High Alarm	3E1C	2.01dBm
26-27	2	TX Power Low Alarm	0640	-7.96dBm
28-29	2	TX Power High Warning	3138	1dBm
30-31	2	TX Power Low Warning	07D0	-6.99dBm
32-33	2	RX Power High Alarm	3138	1dBm
34-35	2	RX Power Low Alarm	0064	-20dBm
36-37	2	RX Power High Warning	2710	0dBm
38-39	2	RX Power Low Warning	007E	-19dBm
40-55	16	Reserved	FF	-
56-59	4	RX_PWR(4)	00000000	0
60-63	4	RX_PWR(3)	00000000	0
64-67	4	RX_PWR(2)	00000000	0
68-71	4	RX_PWR(1)	3F800000	1
72-75	4	RX_PWR(0)	00000000	0
76-77	2	TX_I(Slope)	0100	1
78-79	2	TX_I(Offset)	0000	0
80-81	2	TX_PWR(Slope)	0100	1
82-83	2	TX_PWR(Offset)	0000	0
84-85	2	T(Slope)	0100	1
86-87	2	T(Offset)	0000	0
88-89	2	V(Slope)	0100	1
90-91	2	V(Offset)	0000	0
92-94	3	Reserved	00	-
95	1	Checksum		-

Mechanical (mm)

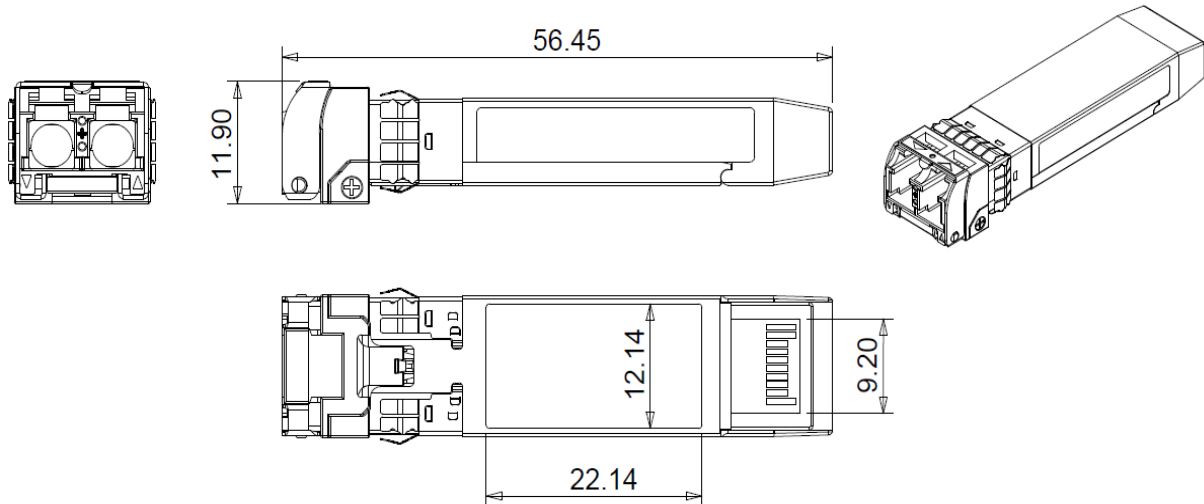

ESD

This transceiver is specified as ESD threshold 2kV for all electrical input pins, tested per MIL-STD-883, Method 3015.4 /JESD22-A114-A (HBM). However, normal ESD precautions are still required during the handling of this module. This transceiver is shipped in ESD protective packaging. It should be removed from the packaging and handled only in an ESD protected environment.

LASER Safety

This is a Class 1 Laser Product according to IEC 60825-1:1993:+A1:1997+A2:2001. This product complies with 21 CFR 1040.10 and 1040.11 except for deviations pursuant to Laser Notice No. 50, dated (July 26, 2001)